

2-090.01 Sliding Cap

Swinghandle Accessory - for use with Product System 2-090, 2-091, 3-150 and 3-151



Product Notes:

- Protects the cylinder
- Automatically closes
- More difficult for vandale to break off
- Used with all swinghandles that have existing dustcovers that swivel to open
- Can used with 40 and 45mm and raised profile cylinders

Material:

- **Sliding cap:** Zinc Die, Black
- **Axis seizing collar:** Stainless Steel

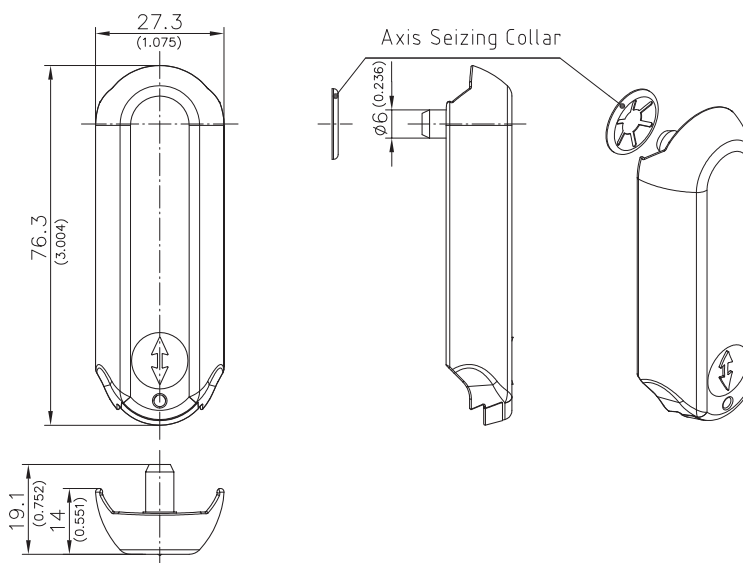
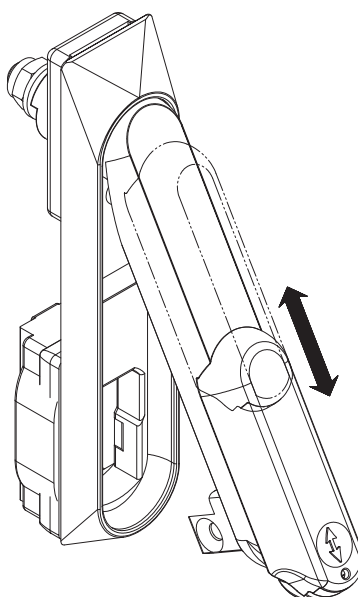

Sliding Cap

Part No.
207-9702

Addition to Page
02.18, 02.26, 02.22, 02.27