

2-078SL Swinghandle RS 110 SNAP-LINE

Tool-less installation, Key actuation, IP65, Cutout 110, Round rods



Product Notes:

- Uses 3-point cam and round rods
- Low profile design
- Pre-assembled swinghandle (single or 3-point cam) can be inserted into cutout and with simple push secured in panel
- Limiting stop at 90° prevents the cam from being over rotated
- RH and LH application
- Water and dust tight according to IP65, DIN EN 60529
- Uses round cylinder DIRAK 1333 with stainless steel dustcap. Key has synthetic coated grip
- NOTE: H-dimension of cam ≥10mm (0.394inch)
- Alternate installation - see Product System 2-079SL

Material:

- **Swinghandle:** Zinc Die, Black
- **Dish:** PA6, Black
- **Rotating dish and bottom:** Zinc Die
- **Wings:** Sintered Steel, Zinc Plated
- **Spring:** Spring Steel
- **O-Ring:** NBR Perbunan
- **Seal:** Polyurethane
- **Serrated screw and cylinder cam:** Steel, Zinc Plated

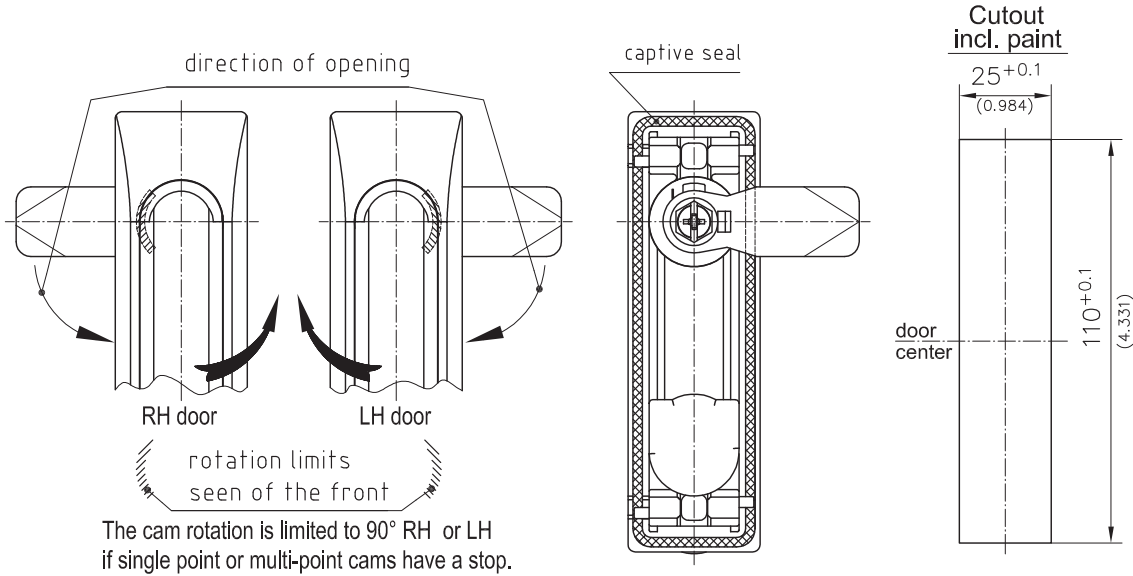

For tailored rods on product system 1-180 the length L-in case of symmetrical doors (as drawn) is:

$$L = \frac{\text{clearance} - 12\text{mm}(0.472)}{2(0.079)} - 30\text{mm}(1.181) \quad \text{upper rod}$$

$$L = \frac{\text{clearance} - 12\text{mm}(0.472)}{2(0.079)} + 30\text{mm}(1.181) \quad \text{lower rod}$$

For tailored rods on product system 1-180 the length L-in case of rod control at the door center is:

$$L = \frac{\text{clearance} - 12\text{mm}(0.472)}{2(0.079)}$$

	Clamping Range (S)	Part No.	See Page
a) Swinghandle	1.2 - 1.7	407-9602.00-00015	
	1.7 - 2.2	407-9602.00-00020	
	2.2 - 2.7	407-9602.00-00025	
Other dimensions on request			
b) Cams			01.42,01.100,01.102
c) 3-point cam adapter with stop (incl. 2 c-clips and screw M6x10)		200-9596	03.43
c1) 4-point cam adapter with stop, with eye (incl. 2 c-clips and screw M6x10)		200-9595	03.43
d) Adapter for round rods			03.50
d1) Adapter for round rods			03.49
e) Round rods			03.46, 03.47
f) Rod guide for round rods			03.52, 03.53, 03.51
Tool for uninstallation		292-0306.80-02530	10.17

