

4-123 Concealed Hinge Pr03 120°

Surface mounted door, Door bending 25mm



Product Notes:

- Door leaf for Product System 4-124 and 4-125
- RH and LH application
- By rotating the pivot pin 1/4 turn, the pivot pin is released and the door can be removed

Material:

- **Door leaf and pivot pin:** Zinc Die, Zinc Plated
- **Washer and bowed washer:** Stainless Steel
- **Nut with serrated flange:** Steel, Zinc Plated

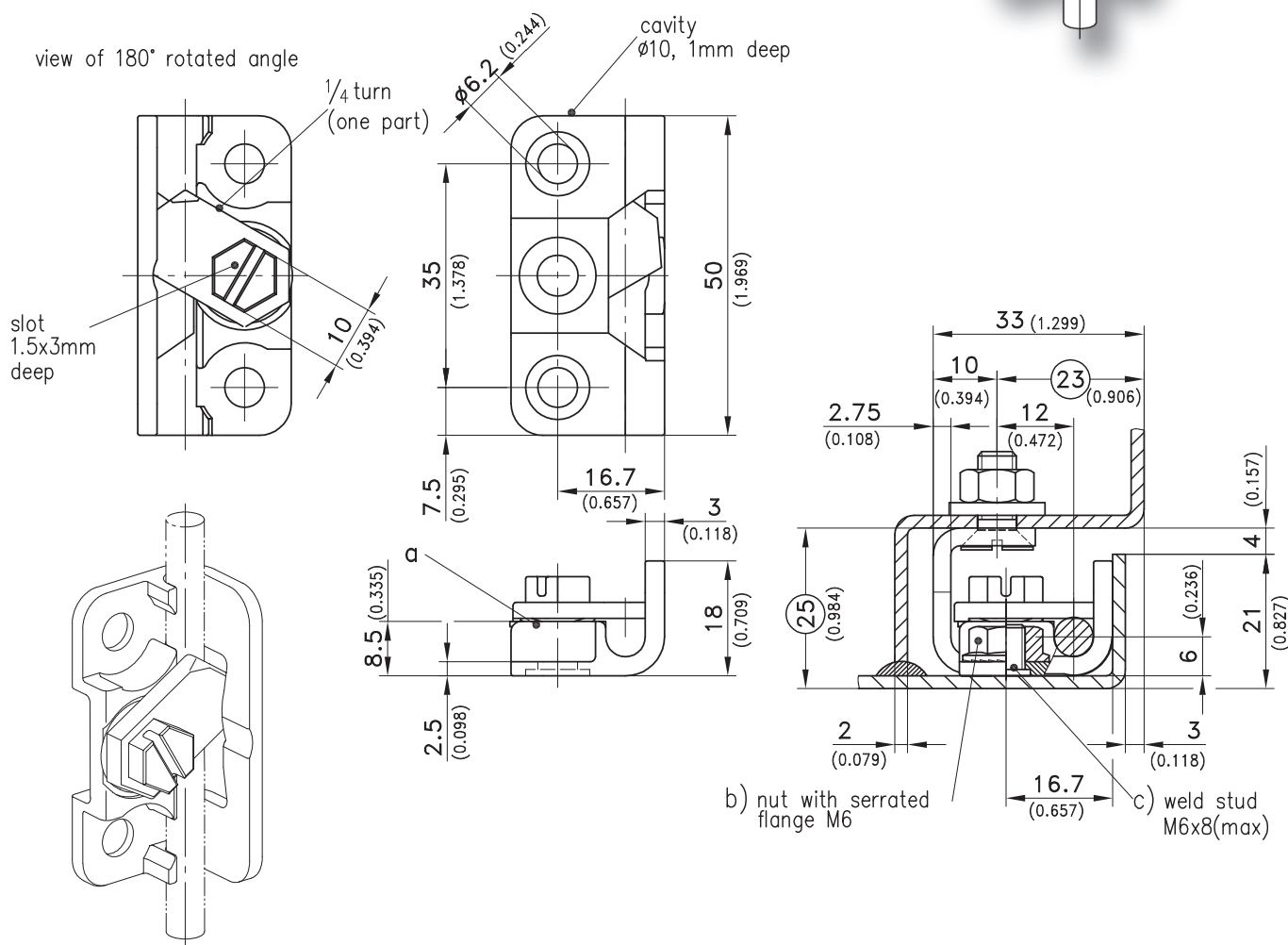
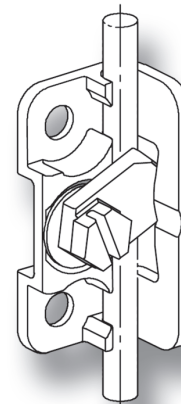

Version	Part No.	See Page
a) Screw-on unit	243-9008	
Please order separately:		
b) Nut with serrated flange M6 (2 pieces per screw-on unit)	860-B193.00-00006	
c) Weld stud M6x8 (2 pieces per screw-on unit)	800-1105	
Part No. of the complete hinge		04.135
This screw-on unit allows also an application with the stainless steel version		04.138
Countersunk machine screws and nuts		10.23