

4-125 Concealed Hinge Pr03 120°

Surface mounted door, Lift-off, Door bending 25mm



Product Notes:

- RH and LH application
- By rotating the pivot pin 1/4 turn, the pivot pin is released and the door can be removed
- Do not use fasten washer with Ø6.3.
- Other Zinc die - see Product System 4-124, 4-124SL and 4-125SL
- Tool-less installation- see Product System 4-124SL, 4-125SL and 7-164SL
- Stainless steel - see Product System 7-164SL 7-165 and 7-166

Material:

- **All parts:** Steel, Zinc Plated
- **Door leaf and 1/4 turn:** Zinc Die, Zinc Plated
- **Frame leaf:** Steel, Zinc Plated

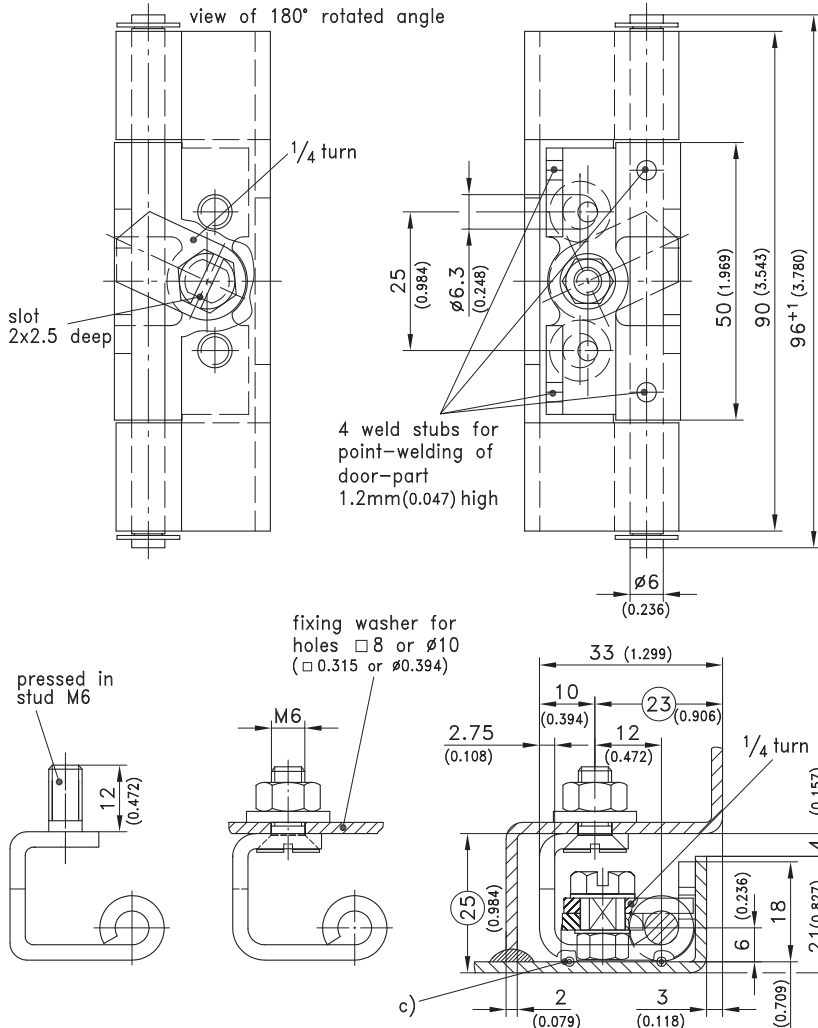
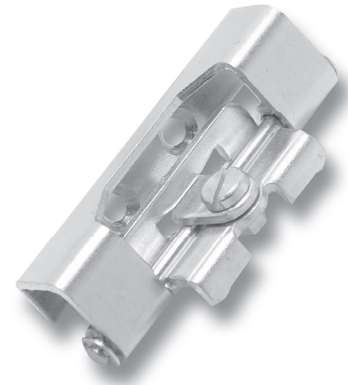

Version with weld-on door leaf	Frame Holes	Part No.	See Page
a) Frame leaf countersunk for M6	Ø6.3 or M6	243-9003	
a1) as a), but with fastening washer	□8 or Ø10	243-9002	
a2) as a) and a1), but with pressed in stud M6 and fastening washer if necessary	Ø6.3, □8, Ø10	243-9007	
Version with screw-on door leaf			04.139
b) Frame leaf countersunk for M6	Ø6.3 or M6	243-9009	
b1) as b), but with fastening washer	□8 or Ø10	243-9010	
b2) as b) and b1), but with pressed in stud M6 and fastening washer	Ø6.3, □8, Ø10	243-9011	
c) 1/4 turn			04.139
Stainless steel version			04.138
Countersunk machine screws and nuts			10.23