

5-130 Window Seals



Product Notes:

- Window seals are used to mount window panes in doors, casings and machine enclosures
- Pane is clamped in place with filler and held flush mounted in the cutout
- Tolerances - see page 05.07
- Material is neutral to paint
- Material has excellent weathering and ozone resistance properties

Material:

- **Profile and filler:** EPDM

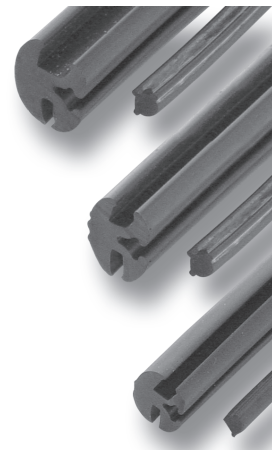

Customized designs:

- If the cross-sections shown are not suitable, customized profile can be developed to meet application need

Example of application

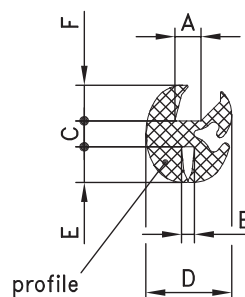
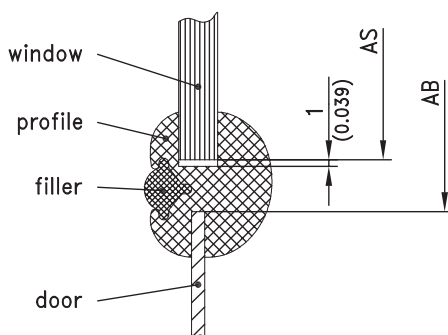

AS=size of window
AB=size of cutout

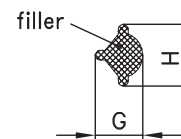

Dimensions mm						Bending Radius mm	Weight g / m	Pack-aging Unit	Part No.	Part No. Filler		
A	B	C	D	E	F				G	H	Packaging Unit 50m	
4	2	4	13.0	5.5	5.5	30	154	20m	209-0501	6	7	209-0601
4	2.5	7	16	7	7	70	235	20m	209-0502	7.5	9.5	209-0602
6	2.5	7	18	7	7	70	270	20m	209-0503	7.5	9.5	209-0602
3	1	4	11.6	4.5	6	35	145	20m	209-0508	6	7	209-0601
4	1.5	7	16	7	7	80	227	20m	209-0509	7.5	9.5	209-0602
4	2	7.3	18	11	8.7	100	405	15m	209-0510	7.5	9.5	209-0602
4.5	5	7	16	7	7	80	300	20m	209-0511	7.5	9.5	209-0602
5	2	7.5	19	12.5	9.5	100	410	15m	209-0512	7.5	9.5	209-0602
5	3	7	19	8	8	90	345	20m	209-0513	7.5	9.5	209-0602
5	3	7.5	19	12.5	9.5	100	460	15m	209-0514	7.5	9.5	209-0602
5	5	7	18.4	9	8	90	360	20m	209-0515	7.5	9.5	209-0602
5.5	2	7.3	19	11	8.7	100	400	15m	209-0516	7.5	9.5	209-0602
6	1.5	7.5	19	12.5	9.5	100	400	15m	209-0517	7.5	9.5	209-0602
6	2.5	7	19	8	8	90	350	20m	209-0518	7.5	9.5	209-0602
6	3	7.5	19	12.5	9.5	100	410	15m	209-0519	7.5	9.5	209-0602
6	4	7.5	19	12.5	9.5	100	390	15m	209-0520	7.5	9.5	209-0602
6	6	8.5	19	9.5	9	100	435	15m	209-0521	7.5	9.5	209-0602
8	3	7.5	22	12.5	9.5	120	600	15m	209-0522	7.5	9.5	209-0602
8	4	8.5	25	12.5	10	100	620	15m	209-0523	7.5	9.5	209-0602
10	3	7.5	23	12.5	9.5	120	600	15m	209-0524	7.5	9.5	209-0602
10	6	7.5	24	12.5	9.5	100	570	15m	209-0525	7.5	9.5	209-0602