

6-166SL Compression Latch SNAP-LINE

Tool-less assembly, Hand operable



Product Notes:

- Low-profile design
- To open - lift and turn lever
To close - turn and fold down lever
- Cam is notched to remain in place when closed
- Latch is pre-assembled
- For added strength a rear bracket can be added
- Clamping range - 5mm - 5.5mm
(0.197 - 0.217)
Accommodate thinner panels with use of rear bracket

Material:

- **Compression latch:** PA
- **Spring:** Spring Steel
- **Pin:** Steel

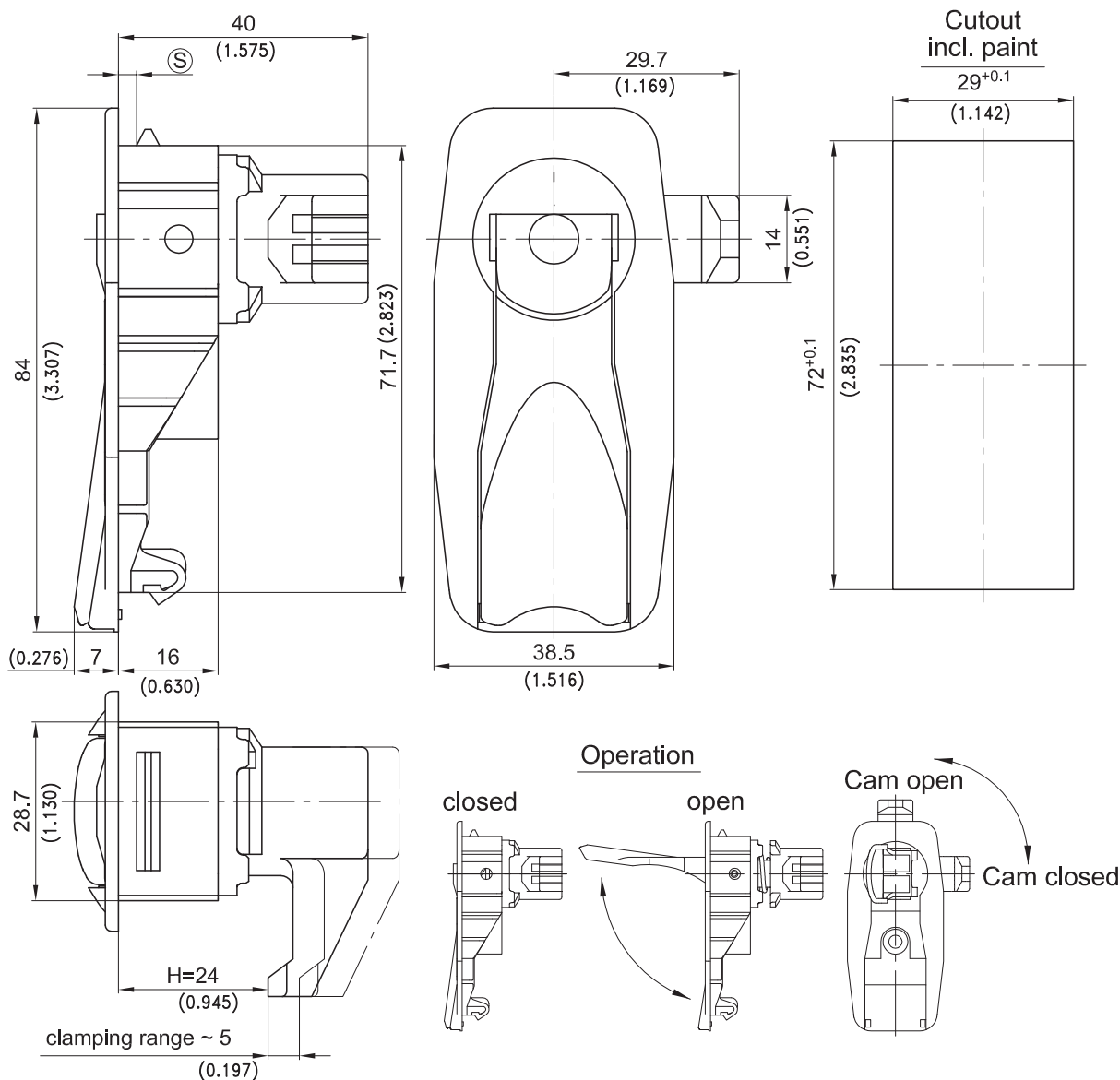

	Part No.
Lever actuated compression latch, left door (as drawn)	282-9008
Lever actuated compression latch, right door	282-9009