

1-043SL Fastener 30x14 SNAP-LINE

Tool-less installation, Tool removeable from front and back, Grounded



Product Notes:

- Fastener for joining flat metal panels
- Clamping Range - 3.0mm - 10.5mm (0.118 - 0.413)
- Join two metal panels by pushing the fastener through the cutouts
- Grounding clip ensures an electrical connection between the panels and the fastener. Grounding clip teeth penetrate the painted edge of the cutouts
- Remove from the front using tool 292-0311.15
- Tool is captive when the fastener is in disengaged position

Material:

- **Housing:** Zinc Die, Black
- **Wings:** Sintered Steel

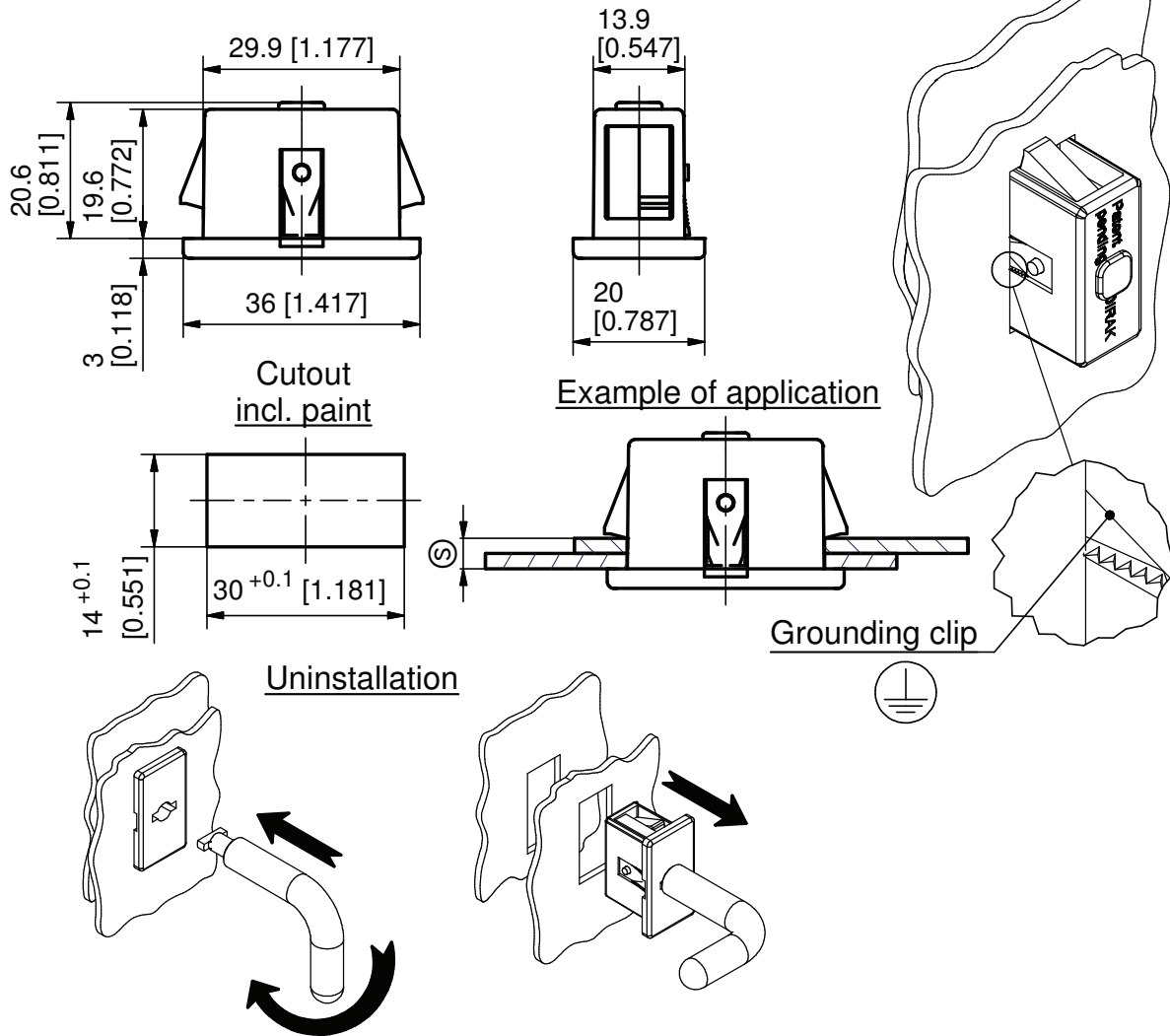

Fastener	Clamping Range [Ⓢ]	Part No.	See Page
	3.0 - 3.7	294-9003.00-00034	
	4.0 - 4.5	294-9003.00-00043	
	5.0 - 5.5	294-9003.00-00052	
	6.0 - 6.5	294-9003.00-00063	
Other [Ⓢ] - dimensions on request			
Cover for cutout 30x14mm		292-0402.00-03014	10.14
Tool for uninstallation		292-0311.15	10.17