

1-041.03SL Fastener 9.5 SNAP-LINE

Tool-less installation, Tool removeable from front



Product Notes:

- Fastener for joining flat metal panels
- Join two metal panels by pushing the fastener through the cutouts
- Fastener is disengaged with screwdriver
- The dimension \textcircled{S} is the total thickness of both panels

Material:

- **Housing:** Zinc Die, Untreated
- **Wings:** Sintered Steel
- **Leaf spring:** Stainless Steel

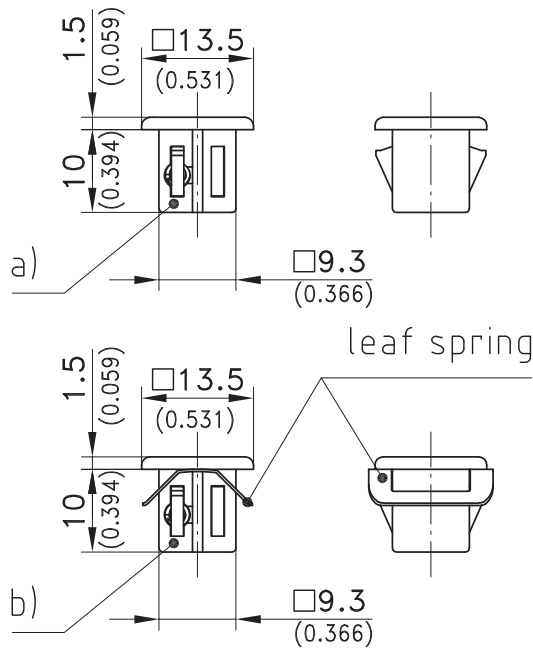

Example of application a)

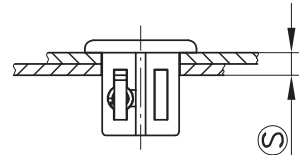

Cutout
incl. paint

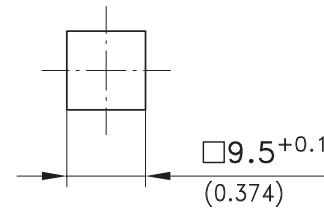

Example of application b)

a) Installation and Removal

b) Installation and Removal rear panel

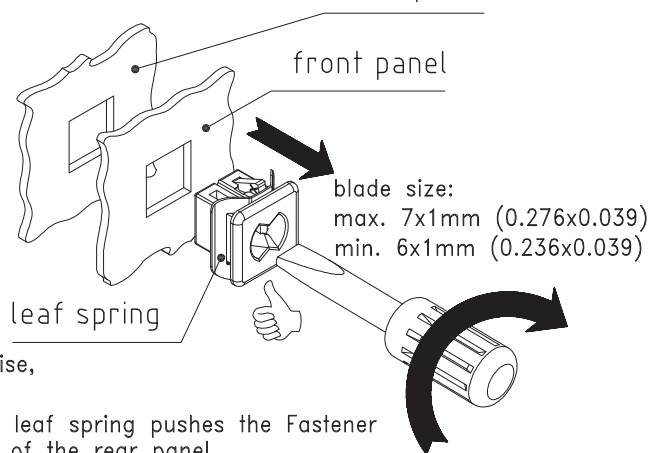
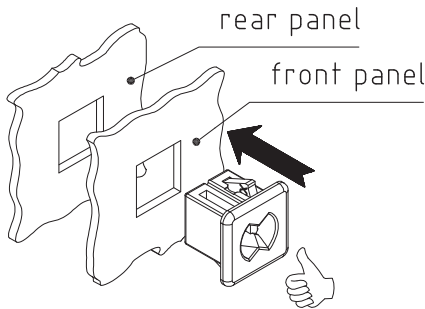

By turning the screwdriver clockwise,
the SNAP wedges retract.

From the rear one can press the
Fastener out of the panel.

The leaf spring pushes the Fastener
out of the rear panel.

	clamping range \textcircled{S}	Part No.
a) Fastener without leaf spring	2.0 - 2.5	294-9117.00-00022*
	3.0 - 3.3	294-9117.00-00031*
	3.4 - 3.7	294-9117.00-00035*
	4.2 - 4.5	294-9117.00-00039*
b) Fastener with leaf spring	1.5 - 2.0	294-9116.00-00047*
	2.5 - 2.8	294-9116.00-00042*
	2.9 - 3.2	294-9116.00-00051*
	3.7 - 4.0	294-9116.00-00055*

*Delivery time on request!