

1-045SL DUAL Fastener 30x10 SNAP-LINE

Tool-less installation, Dual sided - one side hand removeable, one side tool removeable from back



Product Notes:

- Fastener for joining flat metal panels. Dual fastener has one fixed side and one detachable side
- The adjoining page gives an example of one cost saving application - replacing a traditional 3-point latching system using a central latch and DUAL fasteners at both corners of the door. No rods and rod guides are needed. Rattling is also eliminated
- The cutout for the fixed side is 30mm x 10mm.
- The cutout for the detachable side is 28mm - 30mm x greater than 10mm to adjust for possible misalignment.

Material:

- **Dual Fastener:** PA, Black or Zinc Die, Black
- **Other surfaces or colors on request**
- **Wings:** Sintered Steel

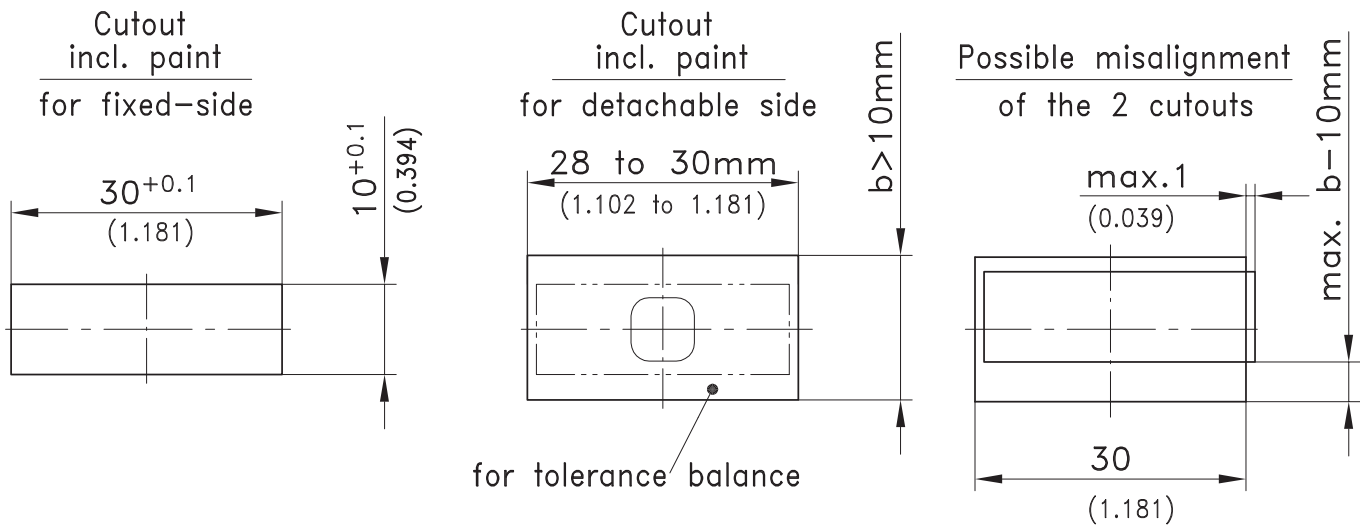

Fixed side: Clamping Range ^⑤	Pull-off Force [Ⓕ]	PA Black	Zinc Die Black	See Page
0.7 - 1.2	~15N	295-9001.52-10001	295-9001.33-10001	
1.2 - 1.7	~15N	295-9001.52-15001	295-9001.33-15001	
1.7 - 2.2	~15N	295-9001.52-20001	295-9001.33-20001	
2.2 - 2.7	~15N	295-9001.52-25001	295-9001.33-25001	
2.7 - 3.2	~15N	295-9001.52-30001	295-9001.33-30001	
0.7 - 1.2	~30N	295-9001.52-10003	295-9001.33-10003	
1.2 - 1.7	~30N	295-9001.52-15003	295-9001.33-15003	
1.7 - 2.2	~30N	295-9001.52-20003	295-9001.33-20003	
2.2 - 2.7	~30N	295-9001.52-25003	295-9001.33-25003	
2.7 - 3.2	~30N	295-9001.52-30003	295-9001.33-30003	
0.7 - 1.2	~50N	295-9001.52-10005	295-9001.33-10005	
1.2 - 1.7	~50N	295-9001.52-15005	295-9001.33-15005	
1.7 - 2.2	~50N	295-9001.52-20005	295-9001.33-20005	
2.2 - 2.7	~50N	295-9001.52-25005	295-9001.33-25005	
2.7 - 3.2	~50N	295-9001.52-30005	295-9001.33-30005	
Cover for cutout 30x10mm		292-0401.00-03010	292-0401.00-03010	10.14
Reinforcement plate for cutout 30x8 and 30x10mm		292-0702.15-01030	292-0702.15-01030	10.16
Tool for uninstallation		292-0306.80-02530	292-0306.80-02530	10.17

1-045SL DUAL Fastener 30x10 SNAP-LINE

Tool-less installation, Dual sided - one side hand removeable, one side tool removeable from back

